



ibaRackline-PC CAM/HD

iba Industrial Computer

Manual

Issue 1.5

Measurement Systems for Industry and Energy

www.iba-ag.com

Manufacturer

iba AG
Gebhardtstrasse 10-20
90762 Fuerth
Germany

Contacts

Headquarters +49 911 97282-0
Support +49 911 97282-14
Engineering +49 911 97282-13
Email iba@iba-ag.com
Web www.iba-ag.com

This manual must not be circulated or copied, or its contents utilized and disseminated, without our express written permission. Any breach or infringement of this provision will result in liability for damages.

©iba AG 2026, All rights reserved

The content of this publication has been checked for compliance with the described hardware and software. Nevertheless, deviations cannot be excluded completely so that the full compliance is not guaranteed. However, the information in this publication is updated regularly. Required corrections are contained in the following regulations or can be downloaded on the Internet.

The current version is available for download on our website www.iba-ag.com and can be found in the iba Help center docs.iba-ag.com.

Issue	Date	Revision	Author	Version HW/FW
1.5	03-2026	Dust filter replacement	st	1.5

Windows® is a label and registered trademark of the Microsoft Corporation. Other product and company names mentioned in this manual can be labels or registered trademarks of the corresponding owners.

Certification

The product is certified according to the European standards and directives. This product meets the general safety and health requirements.

Other international and national standards were observed.

Contents

- 1 About this documentation 5**
 - 1.1 Target group..... 5
 - 1.2 Notations 5
 - 1.3 Used symbols..... 6
- 2 Scope of delivery..... 7**
- 3 Versions 8**
 - 3.1 Delivery state 8
- 4 Safety instructions 9**
 - 4.1 Intended use..... 9
 - 4.2 Special safety instructions 9
 - 4.3 Mainboard battery..... 11
- 5 Device description..... 12**
 - 5.1 Device views 12
 - 5.2 Indicators 14
 - 5.3 Error monitoring..... 14
 - 5.3.1 Switch diagram ibaOut-State 15
 - 5.4 Default installation position for cards..... 16
- 6 Installing, connecting and first switching on 17**
 - 6.1 Installation 17
 - 6.2 Connecting and first switching on 18
- 7 Installing measuring or additional cards 19**
 - 7.1 Basic procedure 19
 - 7.2 Opening the device..... 20
 - 7.3 Installing ibaOut-State 20
- 8 Maintenance work 24**
 - 8.1 Carry out maintenance work..... 24
 - 8.2 Cleaning or replacing the dust filter 24
 - 8.3 Cleaning and replacing the fan 25
 - 8.4 Replacing the power supply unit 25
 - 8.4.1 Replace power supply slide-in module for redundant power supply unit..... 26

8.4.2	Replacing the complete redundant power supply unit	27
8.5	Restoring/monitoring RAID system with Broadcom RAID controller during operation	29
8.5.1	Troubleshooting for “Error Code 49”	34
8.6	Restoring/monitoring RAID system with Intel® Rapid Storage Technology during operation	35
8.6.1	System with Onboard RAID	35
8.6.2	System with plugged Adaptec RAID controller	37
9	Installing operating system and iba software	43
9.1	Installation	43
9.2	Installing Windows from the recovery medium	43
9.2.1	Select the language	44
9.2.2	Enter the product key	44
9.2.3	Partitioning	45
9.2.4	Completing installation	47
9.3	Windows Updates	47
9.4	Installing antivirus software	47
9.5	Installing iba software	47
10	Technical data	48
10.1	Main data	48
10.2	Electronic components and interfaces	49
10.3	Products	49
10.4	Dimensions	51
11	Support and contact	52

1 About this documentation

This documentation describes operation of the industrial PCs *ibaRackline-PC CAM* and *ibaRackline-PC HD*.

1.1 Target group

This documentation is aimed at qualified professionals who are familiar with handling electrical and electronic modules as well as communication and measurement technology. A person is regarded as professional if they are capable of assessing safety and recognizing possible consequences and risks on the basis of their specialist training, knowledge and experience and knowledge of the standard regulations.

1.2 Notations

In this manual, the following notations are used:

Action	Notation
Menu command	Menu <i>Logic diagram</i>
Calling the menu command	<i>Step 1 – Step 2 – Step 3 – Step x</i> Example: Select the menu <i>Logic diagram – Add – New function block</i> .
Keys	<Key name> Example: <Alt>; <F1>
Press the keys simultaneously	<Key name> + <Key name> Example: <Alt> + <Ctrl>
Buttons	<Key name> Example: <OK>; <Cancel>
Filenames, paths	<i>Filename, Path</i> Example: <i>Test.docx</i>

1.3 Used symbols

If safety instructions or other notes are used in this manual, they mean:

Danger!



The non-observance of this safety information may result in an imminent risk of death or severe injury!

Observe the specified measures.

Warning!



The non-observance of this safety information may result in a potential risk of death or severe injury!

Observe the specified measures.

Caution!



The non-observance of this safety information may result in a potential risk of injury or material damage!

Observe the specified measures.

Note



A note specifies special requirements or actions to be observed.

Tip



Tip or example as a helpful note or insider tip to make the work a little bit easier.

Other documentation



Reference to additional documentation or further reading.

2 Scope of delivery

After unpacking, check that the delivery is complete and undamaged.

The scope of delivery includes:

- Industrial computer *ibaRackline-PC CAM* or *ibaRackline-PC HD*
- Keyboard
- Mouse
- Mains cable
- Documentation (on data medium)

The documentation includes:

- Manual (PDF)
- Subcontractors' documentation (PDF)
- Windows 10 Enterprise Long-Term-Servicing Version or Windows Server Version
- Recovery media (for the ordered Windows version and all associated operating system parameters)
- iba software, optional order
- Hardware driver (motherboard, graphic card)
- 1 iba software license key (dongle), optional with iba software product and installed inside of the device on request of the client
- Serial number (iba-S/N)

3 Versions

- *ibaRackline-PC CAM*: RAID 5 system with 5 3,5" SAS hard disks, 1 redundant power supply unit, 1 RAID controller
- *ibaRackline-PC HD*: RAID 5 system with 5 3,5" SAS hard disks, 1 NVMe-SSD, 1 redundant power supply unit, 1 RAID controller

Enhancement options:

- Server system with Windows Server 2016 or higher
- Hard disk upgrade from 5x 8 TB SAS to 5x 12 TB SAS or to 5x 24 TB SAS
- Additional graphics card

3.1 Delivery state

In delivery state, 2 users with or without password are configured:

User	Password
pda	-
Administrator	xadmin

Note



Change the preconfigured passwords after starting-up the PC. This way, unauthorized usage will be impeded.

4 Safety instructions

Observe the following safety instructions for *ibaRackline-PC CAM/HD*.

4.1 Intended use

The device is an electrical operating resource. It must only be used for the following applications:

- Machine test and commissioning of industrial systems
- Measurement data logging and analysis
- Applications of iba software products (*ibaPDA*, *ibaLogic* etc)

The device can be installed only according to manufacturer's specifications:

- 19" rack
- 19" frame

According to manufacturer's specifications the device can only be installed on an even non-slip installation surface, for example table or rack.

Note



The plug of the system serves for disconnecting the device. Therefore, the plug as well as the socket must always be easily accessible in order to allow a quick disconnection of the power supply.

4.2 Special safety instructions

Danger of electric shock!



Before opening the device disconnect it from the mains and pull out the mains plug from the socket equipped with earthing contact!

Never use the device with a damaged mains cable!

Warning!



This is a class A device. This equipment may cause radio interference in residential areas. In this case, the operator will be required to take appropriate measures.

Warning!

Before opening the device disconnect it from the mains by unplugging the cable from the socket equipped with an earthing contact and wait for several minutes until the components have cooled down! Thus you will avoid injuries due to the electric shock or burns!

Connect the device to one supply voltage only according to specifications on the built-in power supply unit!

Always use a socket equipped with earthing contact! Use a terminal strip with overvoltage protection or an uninterruptible power supply (UPS)!

Always connect the device to earthed power networks (TN-networks according to VDE 0100 Part 300 and IEC 60364-3)! The operation via ungrounded networks or networks (IT networks) earthed via impedance is not permitted!

In case of faults, a defective device or a possible defect unplug the mains plug from the grounded socket immediately!

Never put a damaged device into operation!

Pay attention to sharp edges in the housing!

Never switch off the device by means of the mains switch without previous shutdown of the device.

Caution!

Electrostatic discharges can damage the computer! To avoid electrostatic ESD damage, discharge your body electrically before touching the components.

Caution!

Before working on or dismantling the device, disconnect it from the power supply.

4.3 Mainboard battery

The computer contains 1 CMOS battery CR2032, included in the mainboard used. The battery is a lithium metal battery and belongs to the following class of dangerous goods: UN3091 Class 9 – PI970 Section II - SP188. The cells are not subject to some requirements of dangerous goods regulations. The currently valid safety data sheet of CR2032 is available on request.

Observe the correct polarity of the battery.

Note



Used batteries and rechargeable batteries must not be disposed of with residual waste.

Batteries contain valuable raw materials that can be recycled and reused. Devices with the symbol are subject to EU Directive 2002/96/EC on waste electrical and electronic equipment. As a manufacturer we are obliged under the above directive to make you aware of this directive in the context of selling batteries or rechargeable batteries.

Batteries must not be disposed of in the household waste. This is highlighted by a crossed-out rubbish bin or waste container. You are legally required to properly dispose of batteries. Please dispose of spent batteries as required by law at municipal collection centers or return them to your local retailer free of charge. It is expressly forbidden to dispose of batteries in the household waste; this is harmful for the environment. Batteries delivered by us can be returned free of charge or returned by mail with sufficient postage.

5 Device description

In the following you will find views and descriptions of *ibaRackline*.

5.1 Device views

Front view



(Image without cover panels)

1	Fan (can be replaced from the front)	5	Reset button
2	USB interface for hidden dongle mounting	6	Power button
3	USB interface	7	Plug-in slots for hard disks
4	LEDs (hard disk indicators)		

Note



On delivery of the device the iba software license key is in the documentation or on client's request plugged-in in the device.

Rear view



1	2x Power supply with switch and panel plug for non-heating appliances, replaceable	4	Slot for controller
2	Slots X20 to X26 (for low-profile iba cards)	5	Free slots X3 to X7 (PCIe), X8 (PCI)
3	Connections for external devices (keyboard, mouse, network etc.)		

Internal view



1	PCI Express slots	5	Drive frame
2	Controller	6	Fan (Ø 12 cm), mounting angle for redundant power supply unit
3	Slots for low-profile iba cards	7	Additional fan (as option)
4	Power supply unit (for RAID systems redundant)		

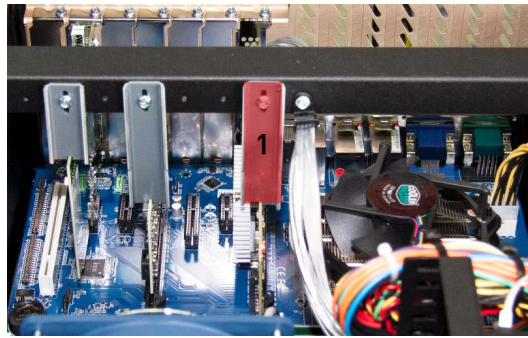

1	Hold-down clamp
---	-----------------

5.2 Indicators

The indicator consists of 2 LEDs.

LED 1: HDD1 (hard disk 1)

LED 2: HDD2 (hard disk 2)

The hard disk controller is connected to the LED 1 and lights up green in case of hard disk activity.

5.3 Error monitoring

The following figure shows a plug-in card *ibaOut-State* in slot X20.

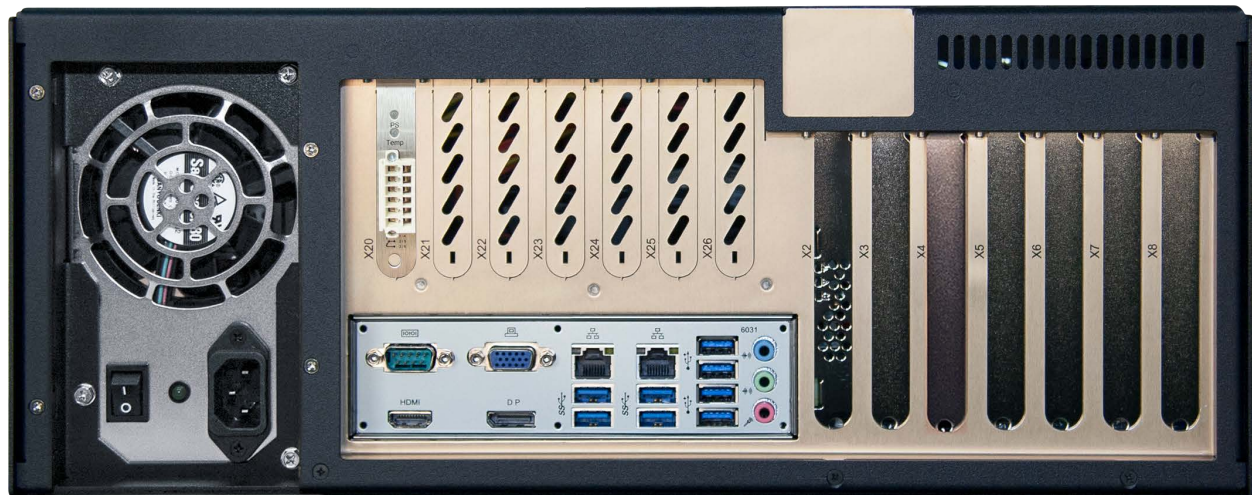

The temperature and the status of the power supply unit can be monitored with the plug-in card *ibaOut-State*. The card can be ordered separately as accessory. If the card is ordered with the PC, it is installed by default in slot X20. If the plug-in card is installed subsequently, please refer to chapter ↗ *Installing ibaOut-State*, page 20.

The status of temperature and power supply unit are indicated each with a bicolored LED:

LED	Status	Description
TEMP	green	Temperature OK
	red	Overtemperature
POWER	green	Power supply OK
	red	Power supply error Redundant power supply: error in one of the two power supply units

5.3.1 Switch diagram ibaOut-State

ibaOut-State provides an output (6-pin connector) which can be used to indicate errors. Both error types are indicated separately.

These are the switch positions:

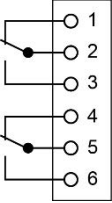
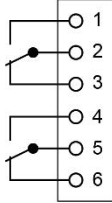
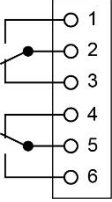
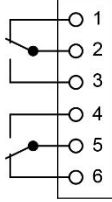
Switch	status	switch	status
	Power OK, temperature OK		Power off or Power error and overtemperature
	Power error temperature OK		Power OK, overtemperature

Contact loading capacity

Nominal current: 300 mA

Nominal voltage: 220 V DC

Compatibility to previous ibaRackline models

The behavior of *ibaOut-State* is identical with the previous models with a relay output, if pin 5 and 6 are used. The relay contact of the previous ibaRackline models is closed when an error occurs, without differentiating between overtemperature or a power supply error.

5.4 Default installation position for cards

On delivery, the data acquisition cards and other additional cards are installed by default in the slots as described below.

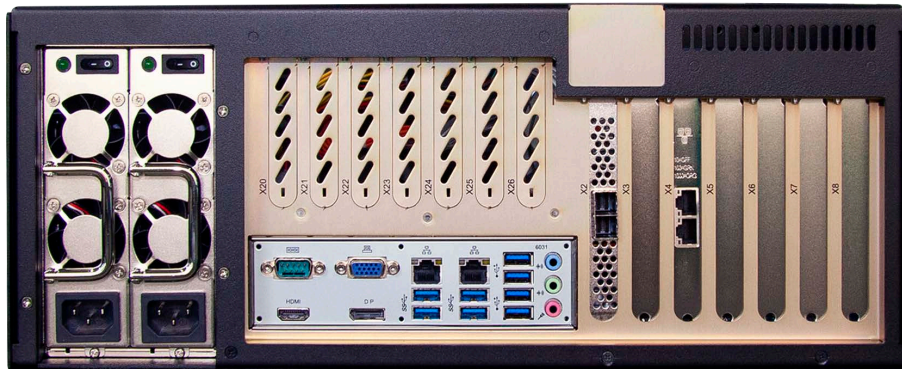

Specific slots for the mainboards

- Slot X2: controller

Installation slots for data acquisition cards (X3 – X7)

- The cards are installed starting with slot X7 to slot X3
(X7 corresponds to the first card, card no. 0)

Installation slots for low-profile cards (rackline slots) (X20 - X26)

- ibaOut-Temp or ibaOutState is installed in slot X20
- ibaFOB-4o-D rackline-slot is installed starting with X25 and connected to X7 downwards.
- ibaFOB-4o-D rackline-slot as sync-out (mirroring output) is installed in X26 and connected to X7

Connections of ibaFOB-4o-D with ibaFOB-xi-D input cards:

- X25 - X7
- X24 - X6
- X23 - X5
- X22 - X4
- X21 - X3

Installation slots for additional network cards

- Additional network cards are installed starting with slot X3
- GigE cards are installed in the slots X4 and X5
- A PCI card is installed in slot X8 (e.g. CP1616)

6 Installing, connecting and first switching on

In the following, you will learn how to *ibaRackline-PC CAM/HD* install, connect and switch on the device for the first time. Also observe the notes in the chapter ↗ *Special safety instructions*, page 9.

6.1 Installation

Proceed as follows to install the device.

Danger of electric shock!



Before opening the device disconnect it from the mains and pull out the mains plug from the socket equipped with earthing contact!

Never use the device with a damaged mains cable!

Warning!



Connect the device to one supply voltage only according to specifications on the built-in power supply unit!

Always use a socket equipped with earthing contact! Use a terminal strip with overvoltage protection or an uninterruptible power supply (UPS)!

Connect the device only to earthed power networks (TN-networks according to VDE 0100 Part 300 or IEC 60364-3)!

The operation via ungrounded networks or networks (IT networks) earthed via impedance is not permitted!

Never put a damaged device into operation!

Note



If you install the device into a 19" rack with rotating frame, consider the depth of the device. Observe the minimum bending radii of the cables.

1. Place the device on the 19" frame from the front.
2. Fasten the device to the 19" frame with 4 screws.
3. Plug in the mains cable of the device into a socket.

6.2 Connecting and first switching on

Note



Before switching on the device for the first time check if the power supply is connected properly and the connecting cable (fiber optic and copper data cable) are plugged. The device is delivered in a pre-installed and configured state. You can find the parameters of the operating system and iba software in the corresponding manuals or in the online help.

1. Connect th device to a mains socket using the mains cable.
2. Connect all cables.
3. Switch on the device using the mains switch.
4. Press the power button to start the device.
→ The computer is booted automatically with Windows.
5. Finally, start all iba software applications.

7 Installing measuring or additional cards

Below you will find information on installing measuring and additional cards in *ibaRackline-PC CAM/HD*. Also observe the notes in the chapter ↗ *Special safety instructions*, page 9.

Danger of electric shock!



Before opening the device disconnect it from the mains and pull out the mains plug from the socket equipped with earthing contact!

Never use the device with a damaged mains cable!

Warning! (risk of injury)



Wait for several minutes after switching off the components have cooled down! Thus you will avoid injuries due to the electric shock or burns!

Pay attention to sharp edges in the housing!

Caution!



Electrostatic discharges can damage the computer! To avoid electrostatic ESD damage, discharge your body electrically before touching the components.

Note



If you upgrade the device, observe the instructions in the third party documentation.

Back up all data on an external storage medium.

7.1 Basic procedure

When carrying out work on the device, proceed as follows:

1. Remove all mobile data carriers (USB sticks, memory cards and so on).
2. Shut down the device.
3. Switch off the device.
4. Unplug the mains cable from the socket.
5. Remove the cover.
6. Carry out upgrade operations.
7. Attach the cover again.
8. Put the device into operation again.

7.2 Opening the device

To open the *ibaRackline-PC CAM/HD* device, proceed as follows:

1. Turn the screws located on the upper side of the cover a quarter of a turn counterclockwise.



2. Lift the housing cover.

7.3 Installing ibaOut-State

The temperature and the status of the power supply unit in *ibaRackline* PCs can be monitored with the slot card *ibaOut-State*.

See also ↗ *Error monitoring*, page 14.

ibaOut-State can be installed in one of the slots X20 to X26 (X20 is recommended).

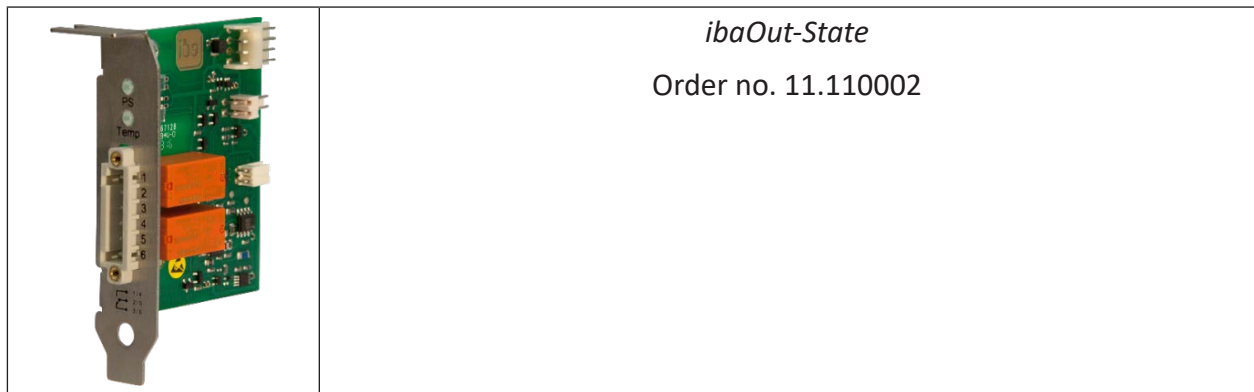

After having opened the housing cover proceed as follows:

1. On the backside of the device, use a screwdriver to remove the cover plate of the designated slot.

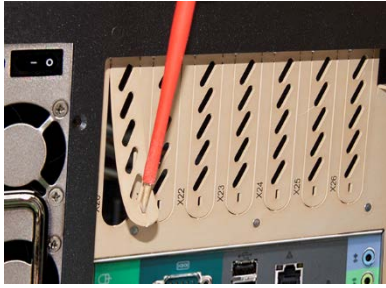

2. Above the slot, there is a screw in an opening, which is used to fix the card later. Loosen the screw and remove it.



Electrostatic discharge!



Touch the components only in electrostatically discharged state! Hold the card cautiously at the edges and at the slot bracket.

3. Insert the card in the respective slot. The bar at the bottom is used to fix the card.



- Fasten the card again with the previously loosened screw.

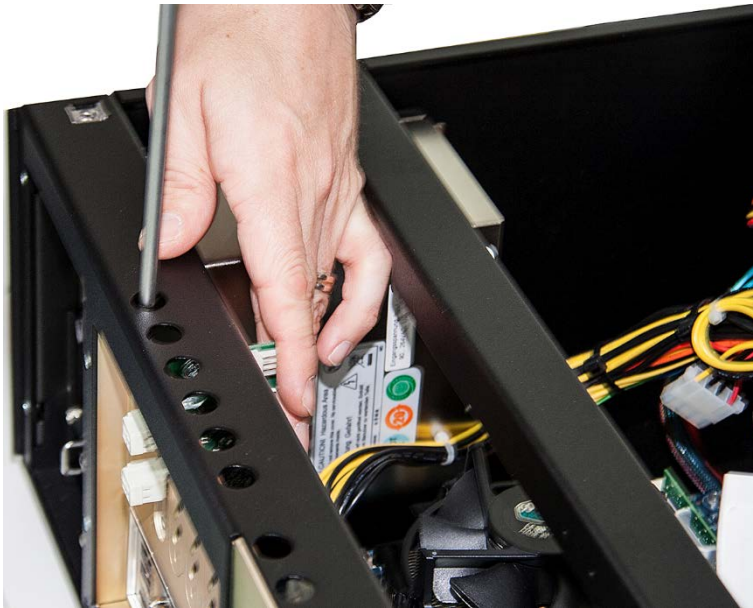

- Connect the cables as follows:

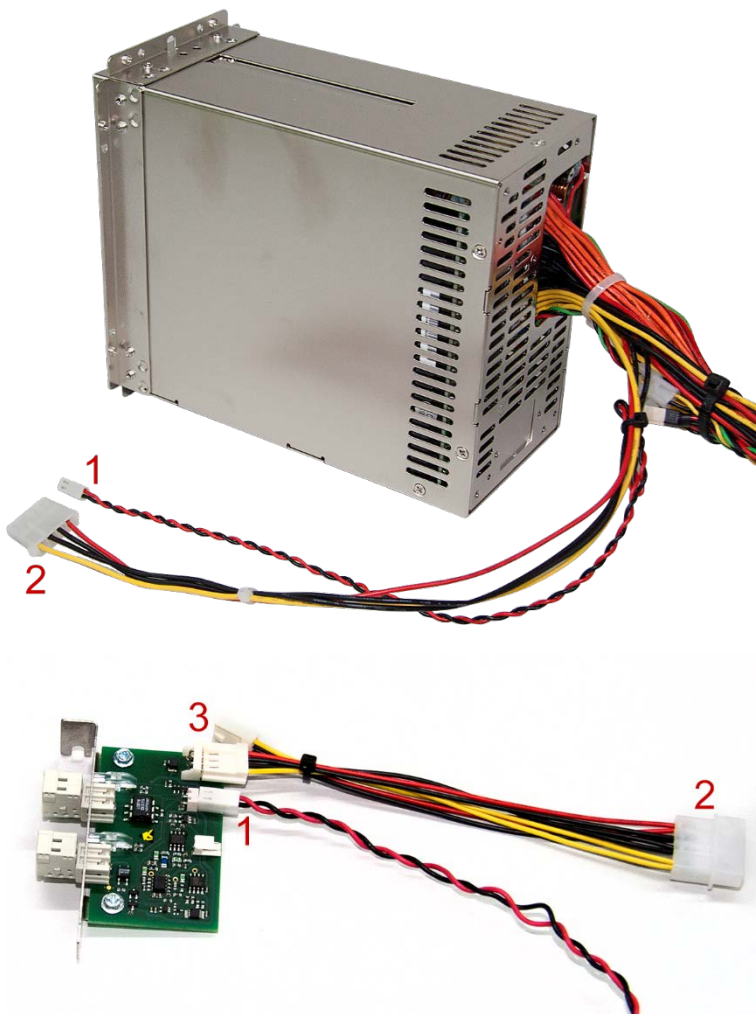

- Connection of redundant power supply unit: If a redundant power supply unit is to be monitored, connect the twisted cable (black/red) of the power supply unit (1 – picture

above) to the 2-pin connector (1 – picture below) of the card. This connection is not necessary, when a standard power supply unit is used.

- b) Power supply connection: Connect the connector of the power supply cable from the power supply unit (2 – picture above) with the wide connector of the cable included in delivery (2 – picture below). Make sure that the cables of the same color are connected. Plug one of the two narrow connectors to the 4-pin connector (3) of the card, the second narrow connector is not used.

6. Properly installed card:



7. Fix the cable with a cable tie and close the housing cover.

8 Maintenance work

In the following, you will learn how to carry out maintenance work on the device.

8.1 Carry out maintenance work

When carrying out maintenance work on the device, proceed as follows:

1. Remove all mobile data carriers (USB sticks, memory cards and so on).
2. Shut down the device.
3. Switch off the device.
4. Unplug the mains cable from the socket.
5. Remove the housing cover.
6. Carry out the maintenance work.
7. Attach the housing cover again.
8. Put the device into operation again.

8.2 Cleaning or replacing the dust filter

Depending on the installation site it is necessary to clean or replace the dust filter in both flaps. The dust filter should be replaced depending on the level of contamination, but at least once a year.

1. Loosen the fastening screw which is used to fix the flap and open the flap.



2. Take the dust filter out of the flap.
3. Clean the dust filter or insert a new one (iba filter mat: order no. 43.000360).
4. Close the flap again and fasten the screw.

8.3 Cleaning and replacing the fan

Depending on the installation site it is necessary to clean or replace the fan. First, remove the grid as described above and proceed as follows:

1. Loosen all 4 fastening screws which are used to fix the fan



2. Pull out the fan towards the front.
3. Unplug the cable connection.
4. Clean the fan or insert a new one.
5. Connect the cables of the fan and the cables of the computer with the cable connector.
6. Insert the fan again.
7. Fasten the fan with the 4 screws at the housing.

8.4 Replacing the power supply unit

If it is necessary to exchange the power supply unit, observe the following instructions and safety instructions.

Danger! Electric shock!



Only qualified professionals are allowed to replace a power supply unit during operation.

Caution!



Electrostatic discharges can damage the computer! To avoid electrostatic ESD damage, discharge your body electrically before touching the components.

8.4.1 Replace power supply slide-in module for redundant power supply unit

If the green lamp of a connected power supply unit is not lit any more during operation, the appropriate power supply slide-in module must be replaced.



1 Fastening screws

1. Loosen the fastening screw which is used to secure the power supply slide-in module at the rack.
2. Pull out the power supply slide-in module.
3. Replace the power supply slide-in module with the module of the same type (available at iba).
4. Fasten the power supply slide-in module with the fastening screw.

8.4.2 Replacing the complete redundant power supply unit

1. First remove the power supply slide-in module, as described above.
2. Loosen the 4 fastening screws on the backside, which are used to fix the power supply unit at the housing.



3. Loosen both screws inside, which are used to fix the power supply unit inside the housing.



- Loosen 2 screws each on the left and the right side, which are used to fix the bar (1) and remove the bar.

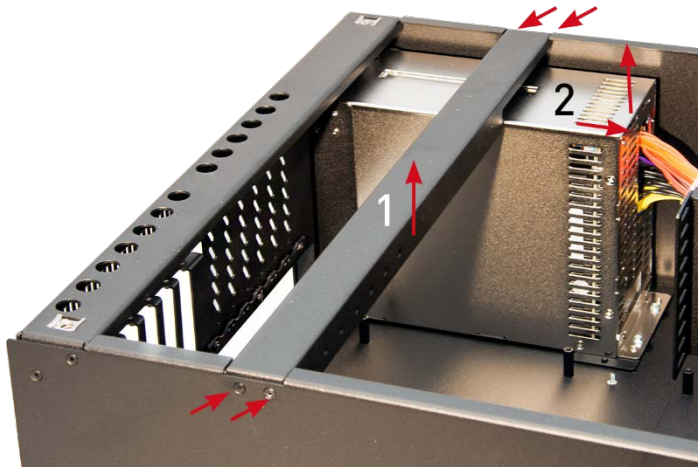

- Disconnect all cable connections to the mainboard and the drives.
- Remove the power supply unit (2) from the housing, by pulling it backwards and lifting it out.
- Remove the mounting angles on the left and right side from the power supply unit by loosening 2 screws from the inner side.



- In order to install a new power supply unit, proceed in reversed order.

8.5 Restoring/monitoring RAID system with Broadcom RAID controller during operation

Danger!



Only qualified professionals are allowed to replace a hard disk/SSD during operation.

Caution!



Electrostatic discharges can damage the computer! To avoid electrostatic ESD damage, discharge your body electrically before touching the components.

Note



The RAID system is automatically restored after the defective hard disk/SSD has been replaced.

Use the "StorCLI" program (Storage Command Line Tool) or the "LSA for Windows" program (LSI Storage Authority Software) for configuration.

Both programs can be found in the hidden directory "C:\OEM" and on the recovery data medium in the directory "Drivers and Manuals".

Using "StorCLI"

"StorCLI" can be started directly from the command line by entering `storcli64`.

Examples of entries:

Information on the existing hard disks and their status (IDs,...)

```
sudo storcli /cx /eall /sall show (all)
```

Information on the existing virtual drives and their status

```
sudo storcli /cx /vall show (all)
```

Show status of all ongoing rebuilds

```
sudo storcli /cx /eall /sall show rebuild
```

Other documentation



Further information can be found in the Broadcom documentation:

<https://techdocs.broadcom.com/content/dam/broadcom/techdocs/data-center-solutions/tools/generated-pdfs/StorCLI-12Gbs-MegaRAID-Tri-Mode.pdf>

Using "LSA for Windows"

"LSA for Windows" must be installed by the user if required. "LSA for Windows" is a web application which requires a web browser, e.g. Internet Explorer.

The program "LSA for Windows" may be configured that the administrator will be informed by e-mail in case of an error.

If you want to configure alarm messages or restore the RAID system, proceed as follows:

1. Start the "LSA" program.

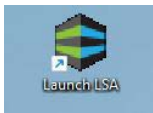

The *Sign in* window is displayed.

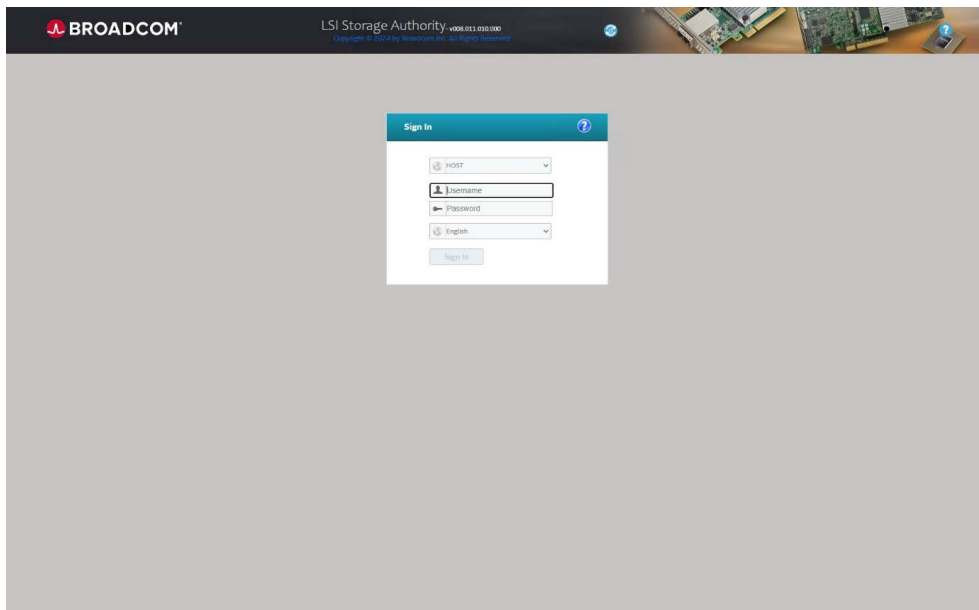

2. Log in as follows:

User Name: administrator

Password: xadmin

Alternatively, any user with admin rights.

If the error message "Error Code 49" appears when logging in, follow the instructions in chapter [➤ Troubleshooting for "Error Code 49", page 34.](#)

3. An overview is displayed.

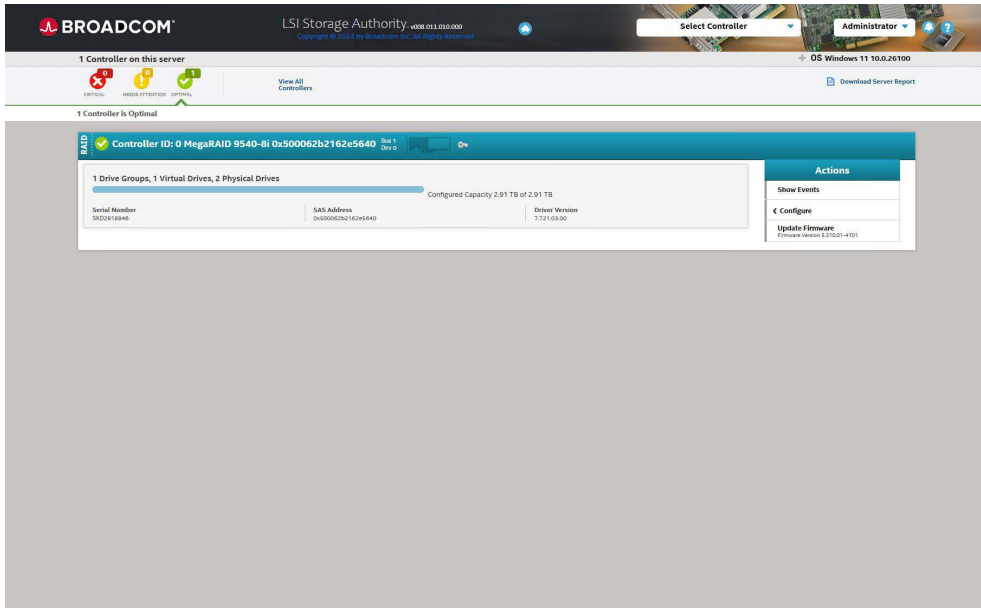

4. Clicking on <Controller ID> opens the view of the virtual (RAID) drives and the physically installed drives.

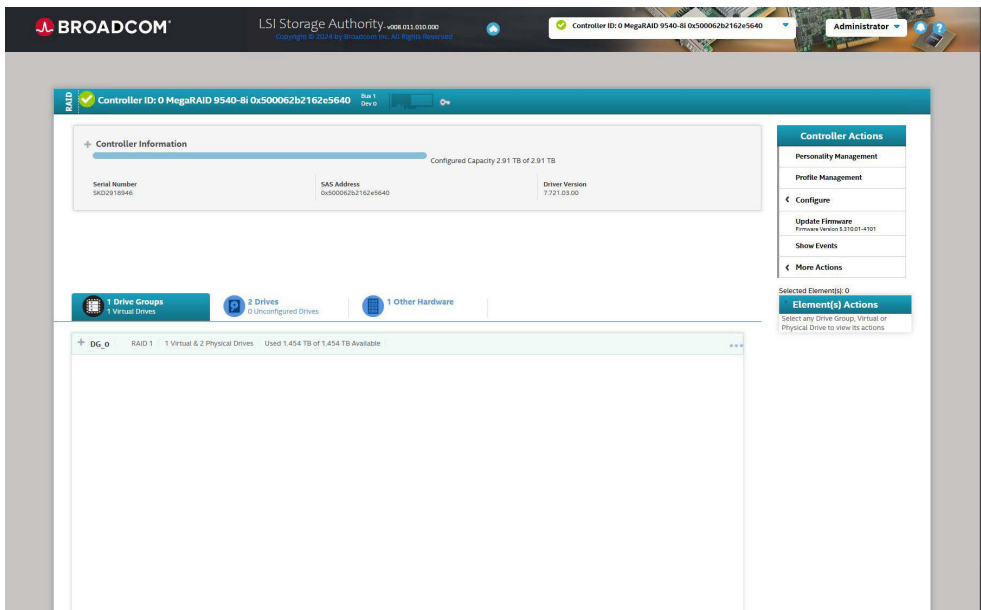

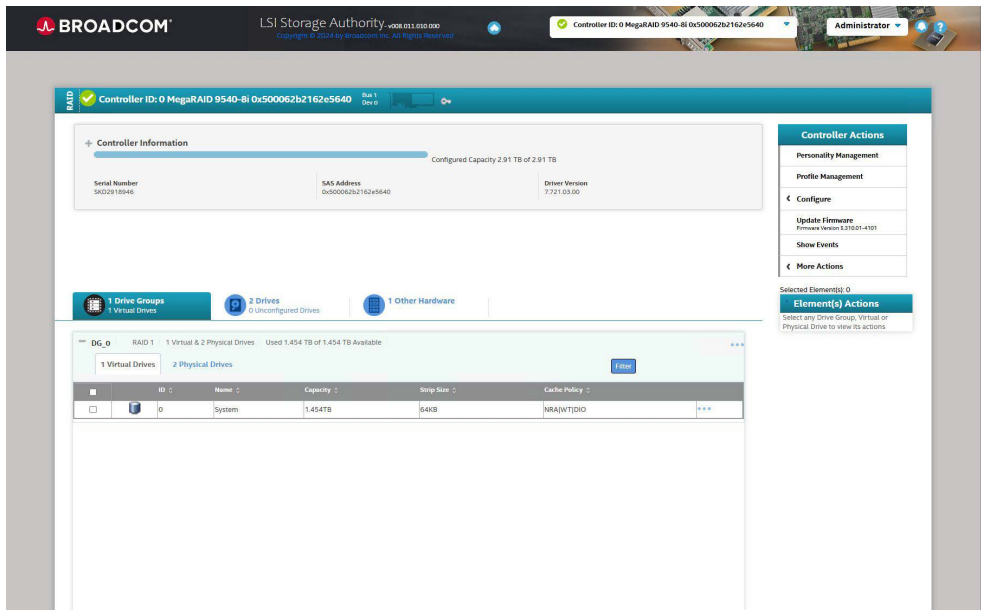

- 5. Select the *Settings* menu from the selection list at the top right. You can configure alerts in the *Alert Delivery* tab.

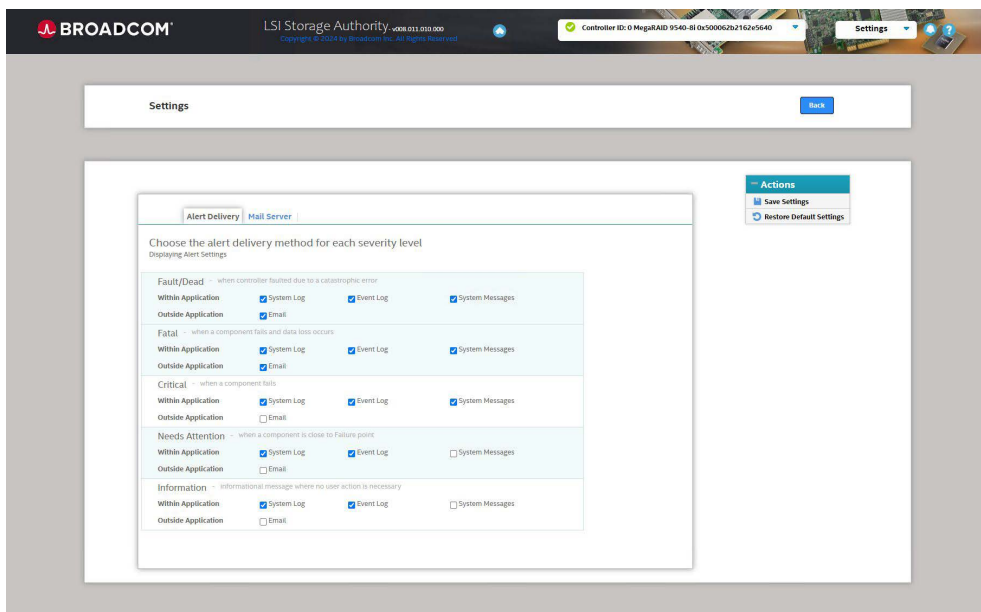

6. You can configure the e-mail notification in the *Mail Server* tab.

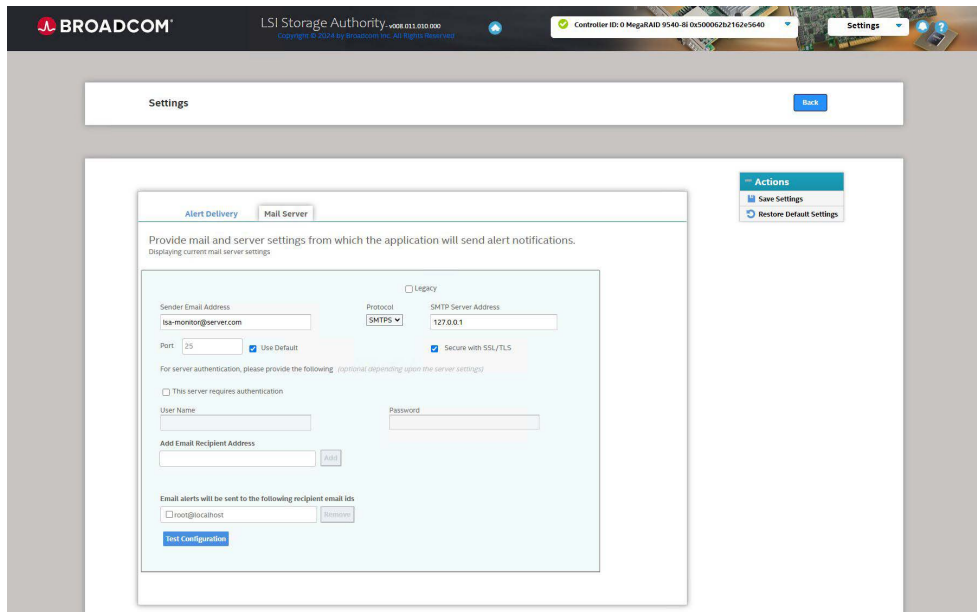

7. If a hard disk/SSD is defective or fails, the restore process is started automatically after the replacement hard disk/SSD has been installed.

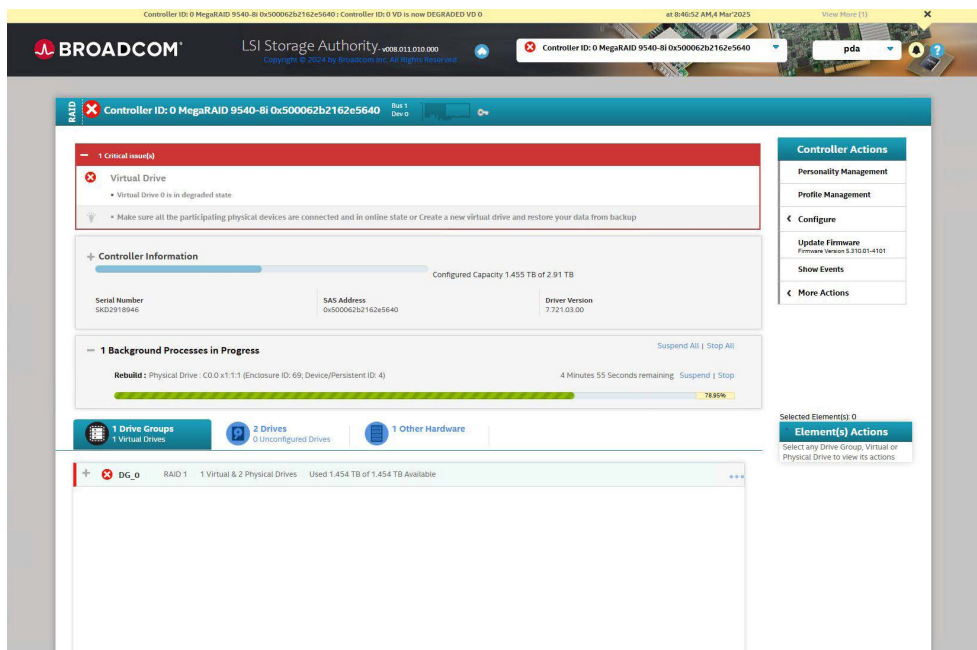

Other documentation



Further information can be found in the Broadcom documentation:

<https://techdocs.broadcom.com/content/dam/broadcom/techdocs/data-center-solutions/tools/generated-pdfs/12Gbs-MegaRAID-Tri-Mode-Software.pdf>

The documentation can be found in the hidden directory "C:\OEM" and on the recovery data medium in the directory "Drivers and Manuals".

8.5.1 Troubleshooting for “Error Code 49”

If the error message “Error Code 49: Invalid Credentials when trying to login to LSA management Software” appears, please note the following information.

Link to the Broadcom documentation:

<https://www.broadcom.com/support/knowledgebase/1211236746276/error-code-49-invalid-credentials-when-trying-to-login-to-lsa>

Error message:

Error Code 49 Invalid Credentials

Error code 49 means: Invalid login information when trying to log in to the LSA management software

Background:

The “LSA” program only fully supports the English operating system.

Other languages are supported, but the `LSA.conf` file must be changed before you can log in to "LSA".

If you are using a native German, French or Spanish operating system, you must edit the `LSA.conf` file and translate “Administrators” into your native language.

Remedy:

1. Stop “LSAService” in the Windows services.
2. Edit the LSA configuration file `LSA.conf`:
`C:\Program Files (x86)\LSI\LSIStorageAuthority\conf\LSA.conf`
3. Search for this line: "full_access_groups = Administrators"
4. Change the *Administrators* keyword to *Administrateurs* (French), *Administratoren* (German) or *Administradores* (Spanish):
French: full_access_groups = Administrateurs
German: full_access_groups = Administratoren
Spanish: full_access_groups = Administradores
Russian: full_access_groups = Администраторы oder Administratory
5. Restart “LSAService”.

8.6 Restoring/monitoring RAID system with Intel® Rapid Storage Technology during operation

Danger!



Only qualified professionals are allowed to replace a hard disk/SSD during operation.

Caution!



Electrostatic discharges can damage the computer! To avoid electrostatic ESD damage, discharge your body electrically before touching the components.

8.6.1 System with Onboard RAID

Proceeding

1. Open the Intel® Rapid Storage Technology enterprise console by double-clicking the icon in the task bar.



2. Now select the corresponding RAID array with the status "Degraded" (1) and click on "Rebuild to another disk" (2) in the volume properties.

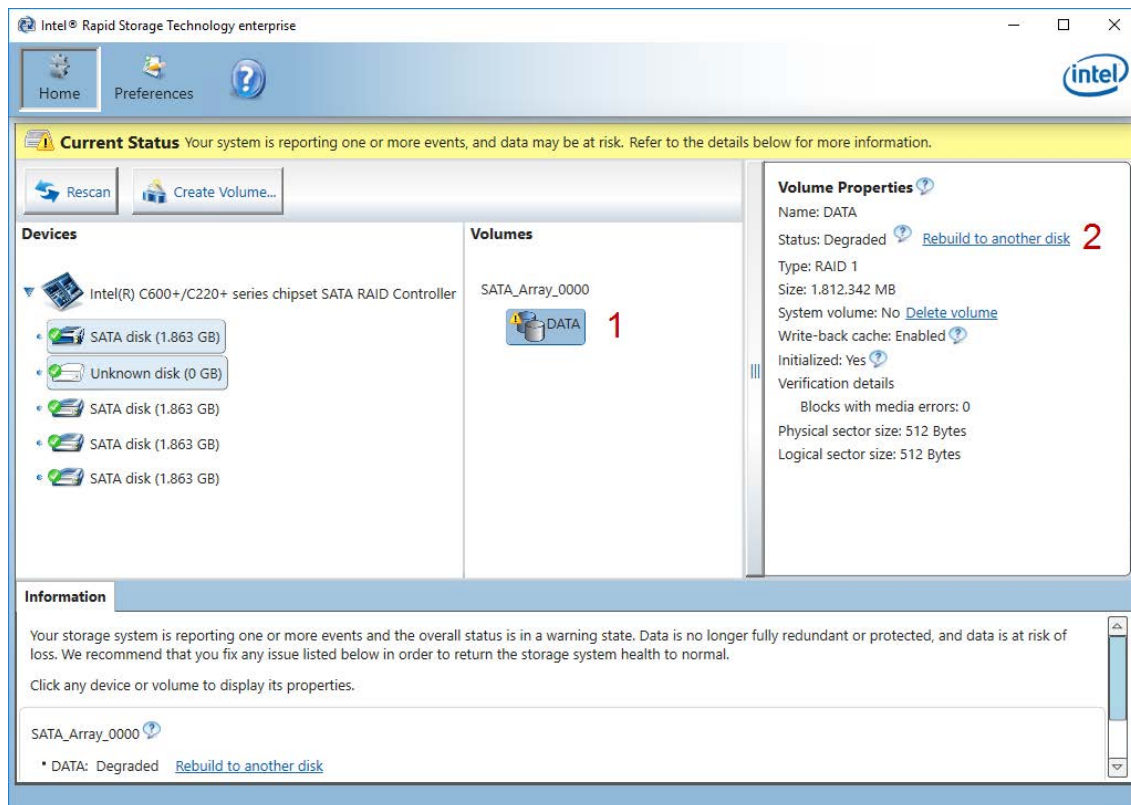

3. In the following dialog select the hard disk that you want to use to restore the redundancy

of the RAID array.

Note



Make sure you have selected the correct drive, because this operation will delete all existing data on the selected drive.

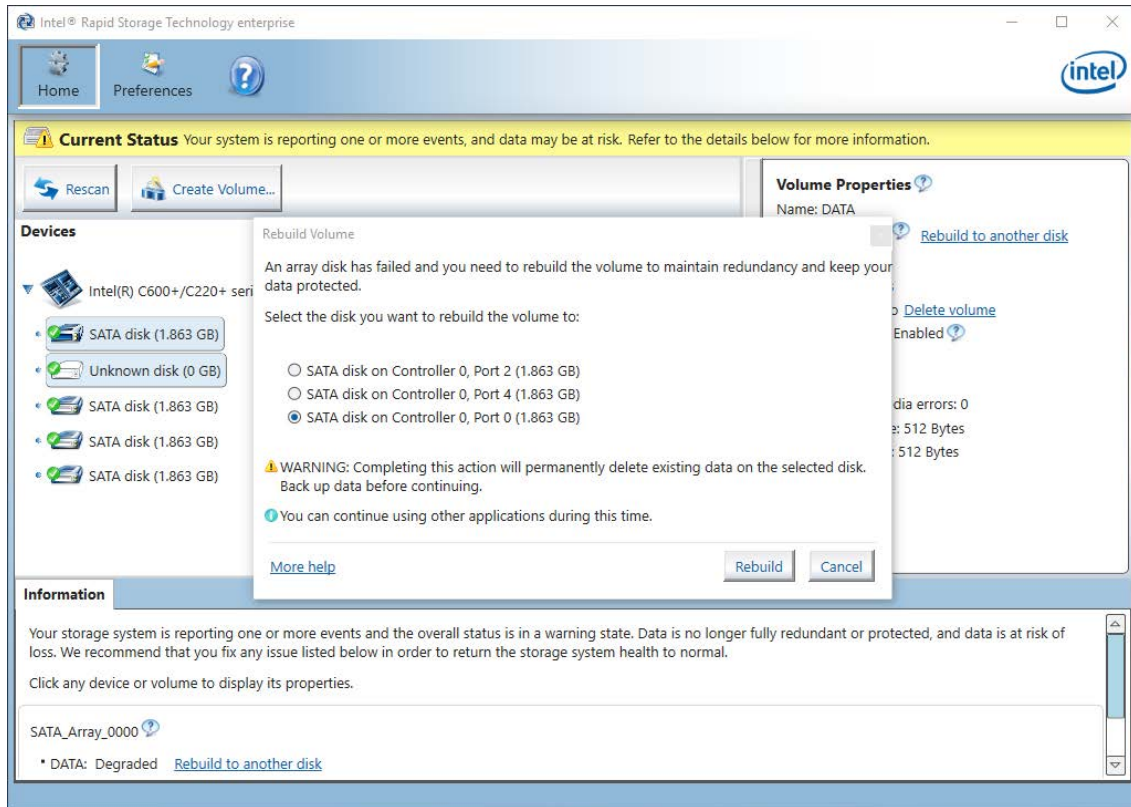

4. Start the process by clicking on <Rebuild>. The duration of the process varies depending on the hard disk capacity.

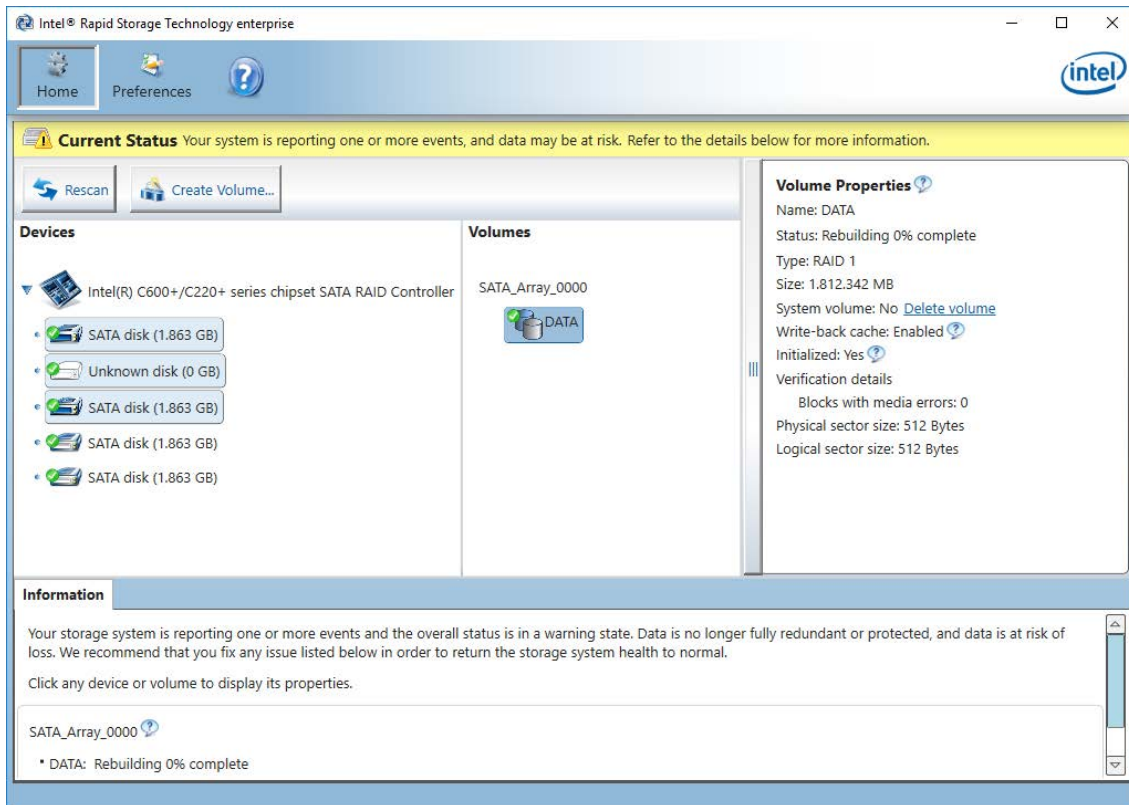

Note



The system performance may be affected during the rebuild process.

→ Once the process is complete, the status in the volume properties must be “Normal” again and the icon in the taskbar must look like this:



8.6.2 System with plugged Adaptec RAID controller

Note



The RAID system is not automatically restored after having changed the hard disk. Use the program “maxView Storage Manager”.

Note



The program "maxView Storage Manager" is included on the data media „Drivers and Manuals“. "maxView Storage Manager" is a web application which requires a web browser, e.g. Internet Explorer.

Note

The program "maxView Storage Manager" may be configured that the administrator will be informed by e-mail in case of an error.

If the buzzer sound can be heard, it is possible that a hard disk in the RAID system is defective. To restore the RAID system, proceed as follows:

1. Start the program "maxView Storage Manager".

The "Log in" window is displayed.

The screenshot shows the login interface for maxView Storage Manager. The title bar reads "maxView STORAGE MANAGER". There are two text input fields: "User Name" containing "administrator" and "Password" containing six dots. A "Login" button is positioned below the password field.

2. Log in as follows:

User Name: administrator

Password: xadmin

3. A click on <Login> opens the program window of the manager. The defective hard disk is not indicated.

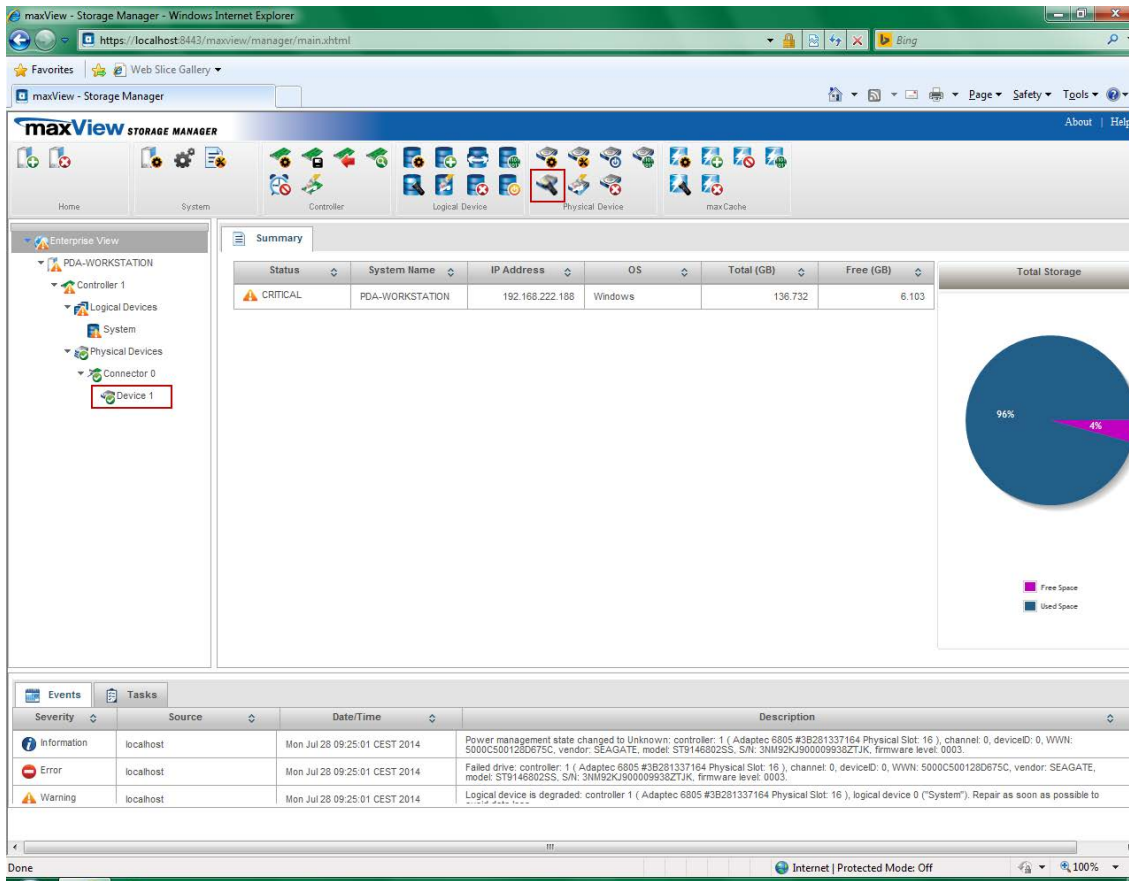

4. Mark the hard disk, which is available (“Device 1” in the example above) and click on the *Locate* icon  in the *Physical Device* section. The LED for the available hard disk flashes in the drive frame.
5. Replace the defective hard disk.

Note



The removal and installation is described in the documentation of the hard disk manufacturer.

→ The new hard disk is indicated in the „maxView Storage Manager“. But the hard disk has not been registered in the system.

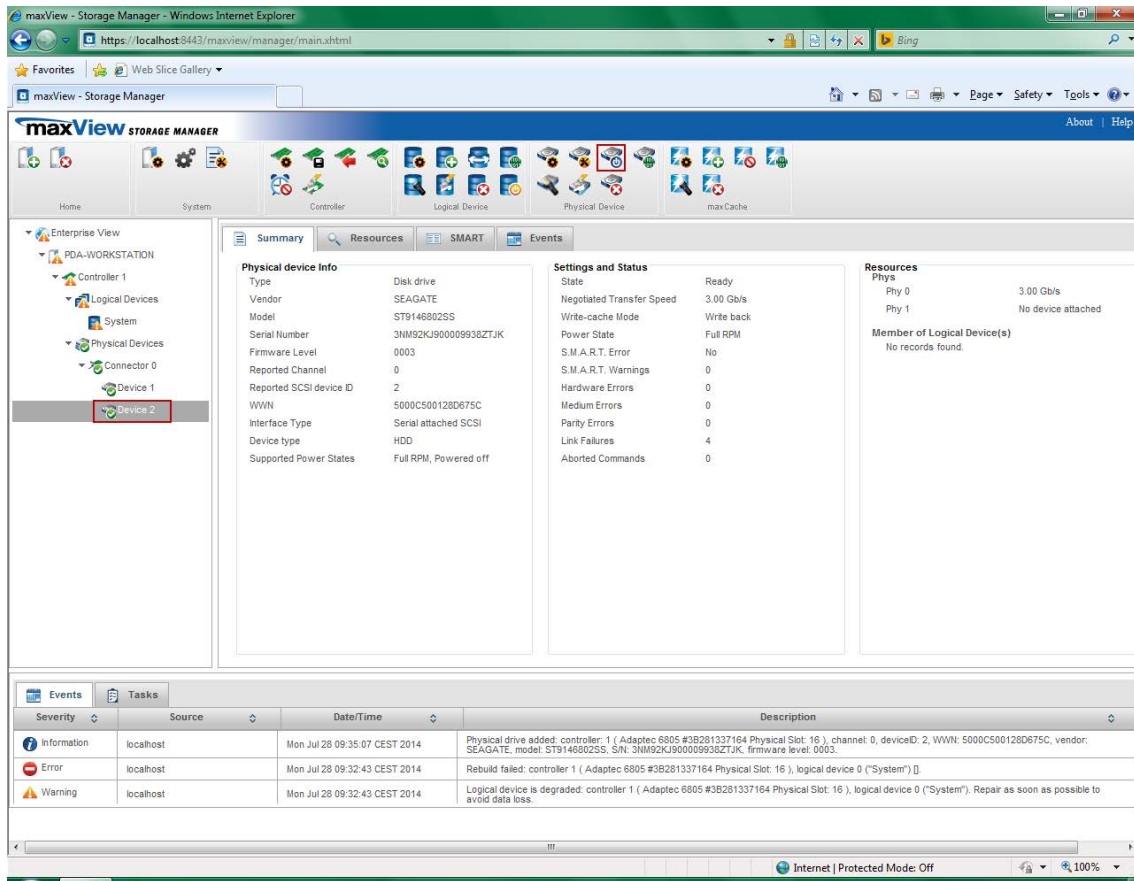

6. Mark the new hard disk ("Device 2" in the example above) and click on the *Initialize* icon  in the *Physical Device* section.

7. Then click on the *Spare Management* icon  in the *Physical Device* section.

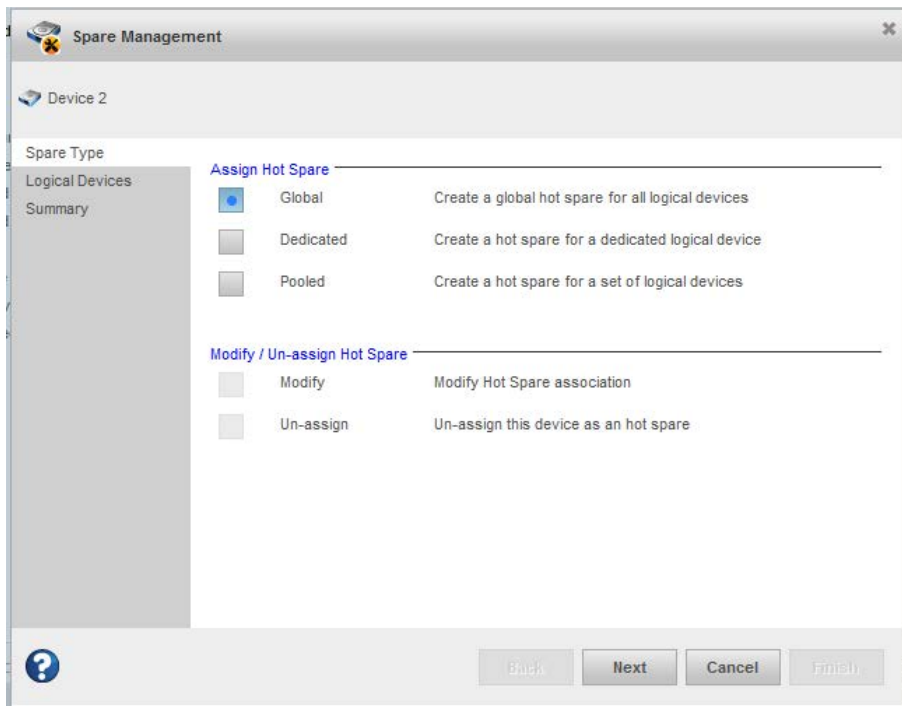

8. Select the *Global* option and click <Next>.

9. Confirm the following overview with <Finish>.

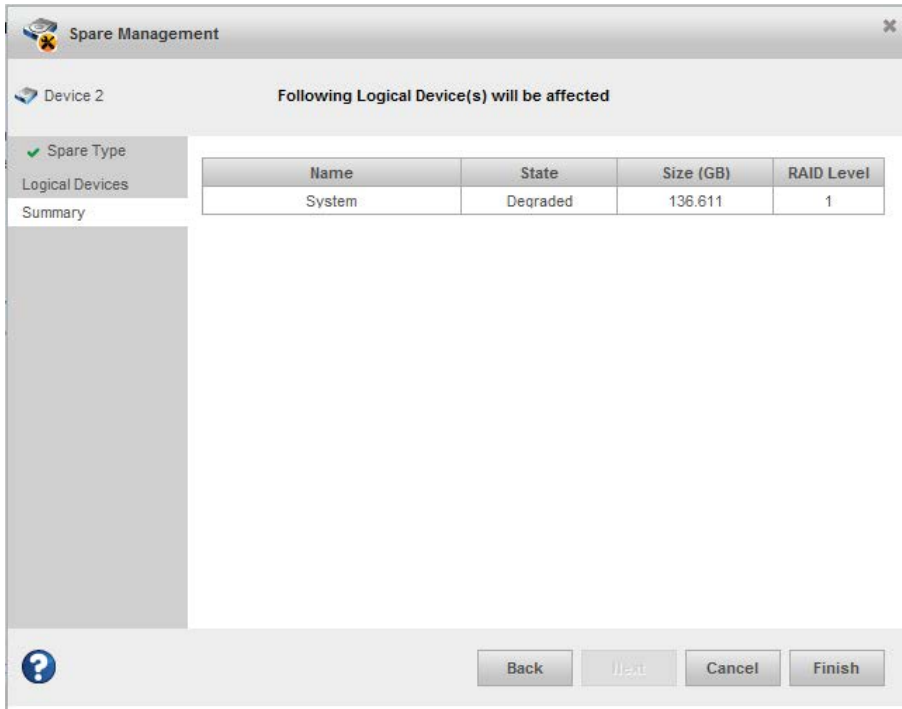

→ The following message appears when the operation was successful.

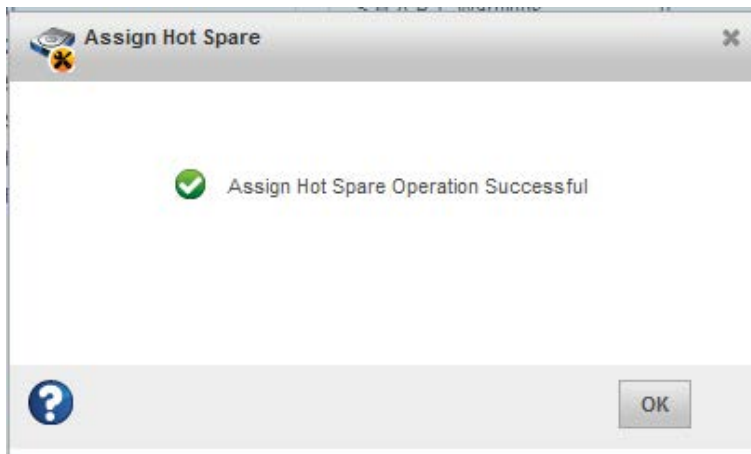

Otherwise an error message appears.

10. The progress of the rebuild process is displayed under *Tasks*.

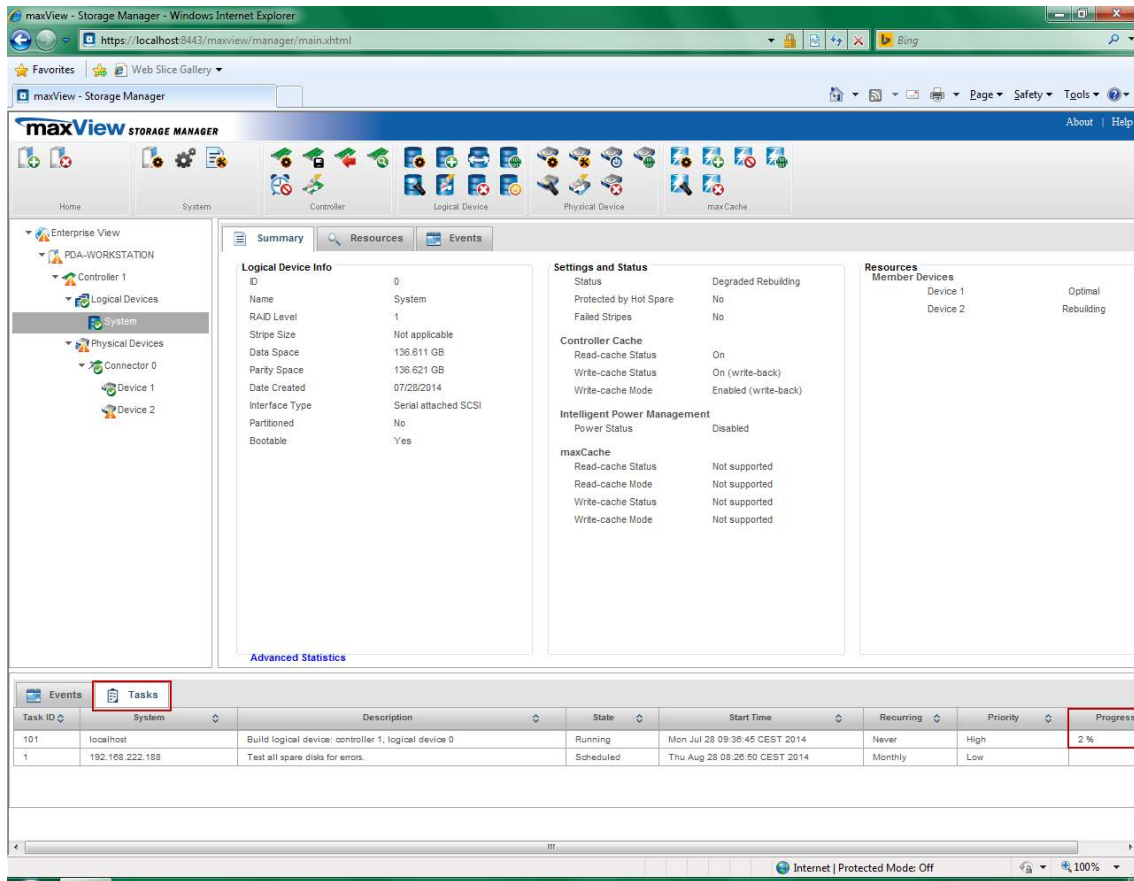

→ As soon as the hard disk has been successfully registered in the system, the program can be closed.

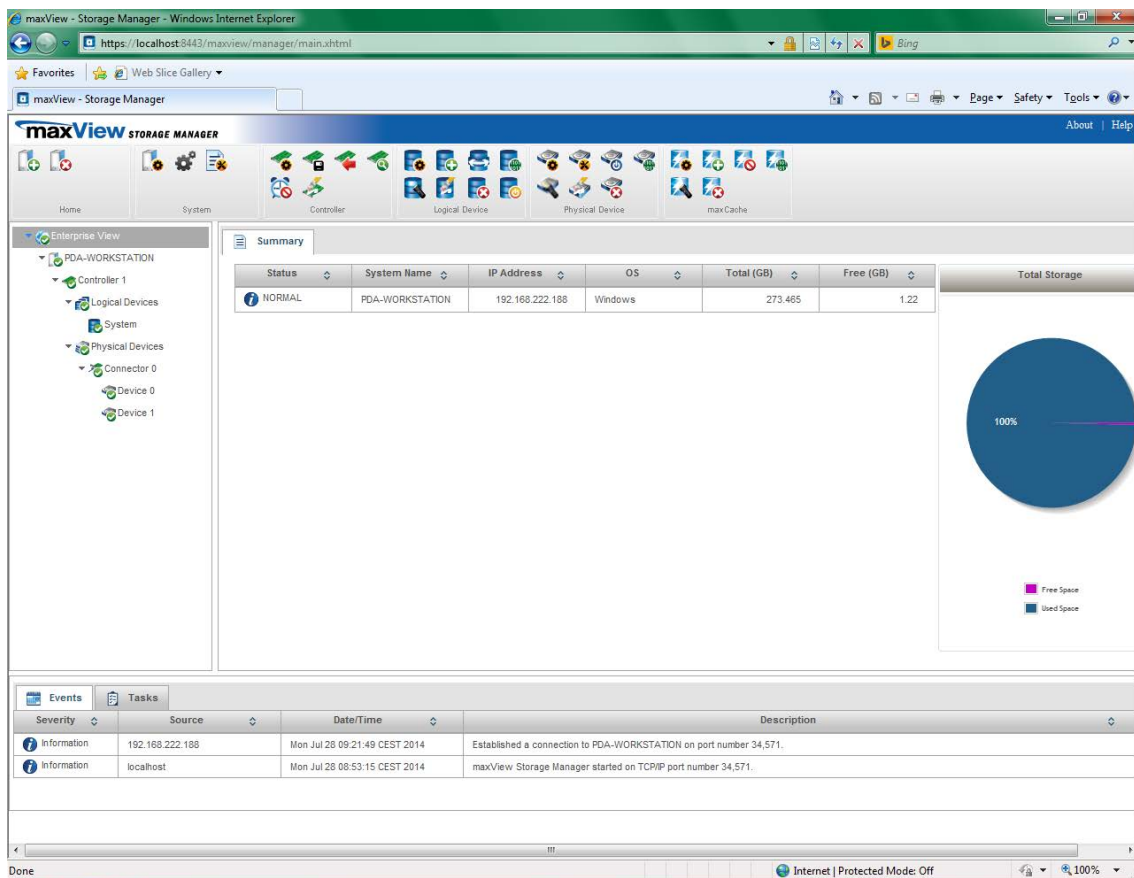

9 Installing operating system and iba software

Below you will learn how to install the operating system and iba software.

9.1 Installation

For the installation of the operating system and the ibaSoftware there are 2 possible ways:

- Install the Windows operating system and the required device drivers (graphic card, hard disk controller etc.).
- Install the operating system using the Recovery media.

Compared to the common installation of the operating system the method named above is advantageous because all required settings and configurations of the device hardware (e.g. drivers) have already been performed on the Recovery media.

The delivery includes the Recovery media for the operating system stated in your order.

Note



If you install the operating system with the Recovery media, all settings and configurations of the device hardware (e.g. drivers) will be installed.

Do not change the basic configuration of the device components (e.g. motherboard)!

If you modify the device components, it may not be possible to install it with the Recovery media.

9.2 Installing Windows from the recovery medium

Note



The Windows license is bound to the computer where iba software is installed. The license must not be used on another computer.

General notes

- If you install the operating system from the Recovery media, the computer must be started from the data media. Make sure, that the required settings in the BIOS are correct.
- The recovery procedure is only available in English.
- The setup routine of Microsoft is used.
- When the recovery procedure is finished, update your Windows version to have the latest safety related version.

- 6 pre-installed languages can be chosen as system language: English, French, German, Italian, Spanish, Russian.

Other languages optionally available.

Note

No liability is accepted for loss of data due to incorrect handling.
Always make sure, that you select the correct drives and partitions.

Note

The recovery process takes approx. 50 minutes. It is possible that only a black or green screen is visible during the process.

9.2.1 Select the language

When the installation has started, you can select the system language to be installed. When using Windows 10 Enterprise or Windows Server the language can be changed subsequently.

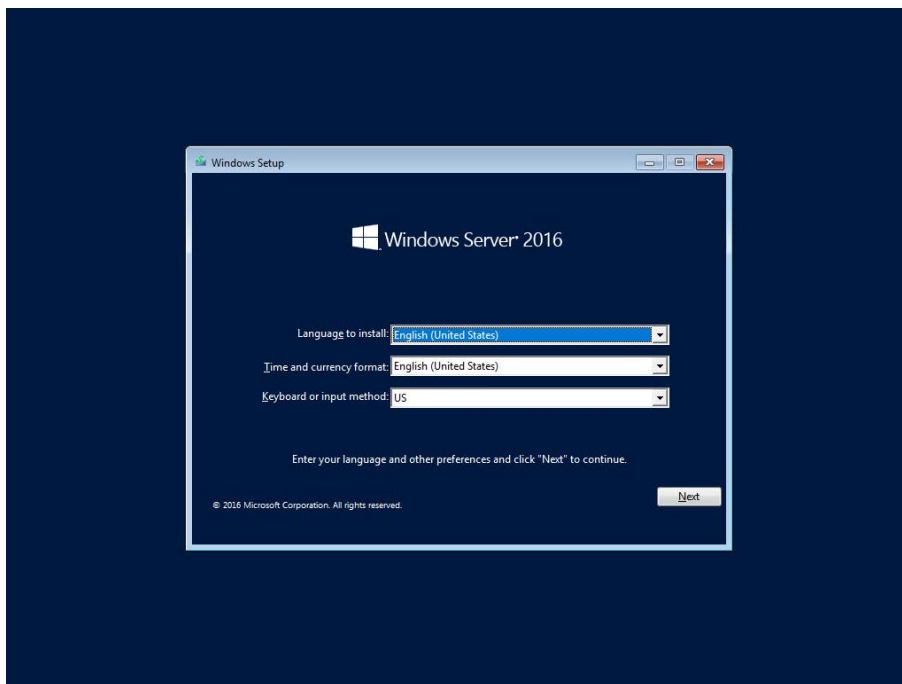

9.2.2 Enter the product key

(only with Windows Server 2016 or higher)

With Windows Server a product key must be entered subsequently.

You will find the product key on the back of the housing.

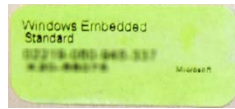

Note



When Windows 10 Enterprise is used, entering the product key or activating the Windows license is not required.

9.2.3 Partitioning

There are several possibilities to set up partitions:

- Set up a new drive completely as system drive
- Set up partitions on a new drive
- Install an operating system on a drive already used (Windows 10 Enterprise or Windows Server)
- Substitute the operating system on a drive already used (substitute Windows 10 Enterprise with Windows Server or vice versa)

Possibility 1: New drive

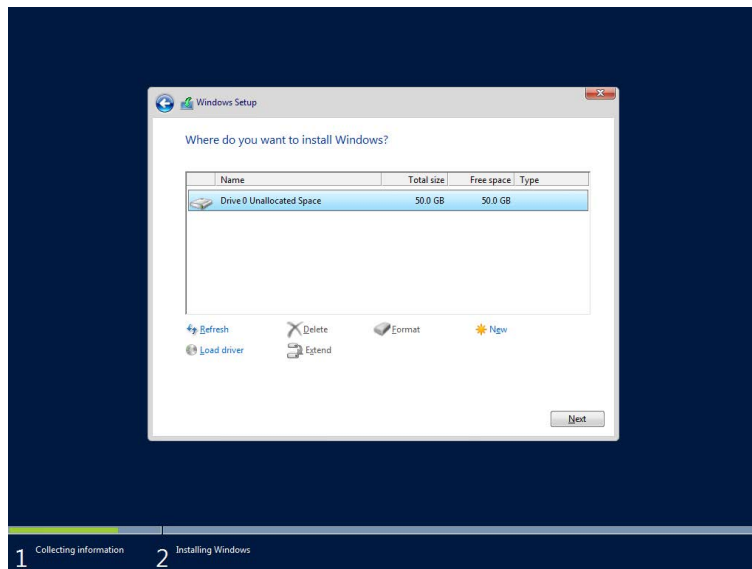

You use a new drive and want to use it completely as system drive.

Click <Next> and continue with chapter ↗ *Completing installation, page 47.*

Possibility 2: Partitioning the new drive

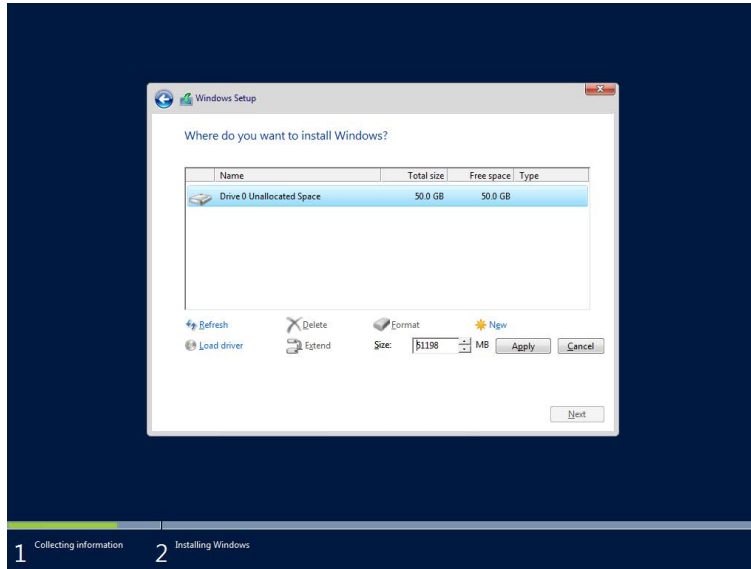

You use a new drive and want to set up partitions.

1. Click <Drive Options (advanced)>.
2. Click <New>.
3. Enter the partition size.
4. Confirm with <Apply>.
5. Mark the partition, where the operating system should be installed.
6. Click <Next> and continue with chapter ↗ *Completing installation, page 47*.

Possibility 3: Restoring or replacing the operating system

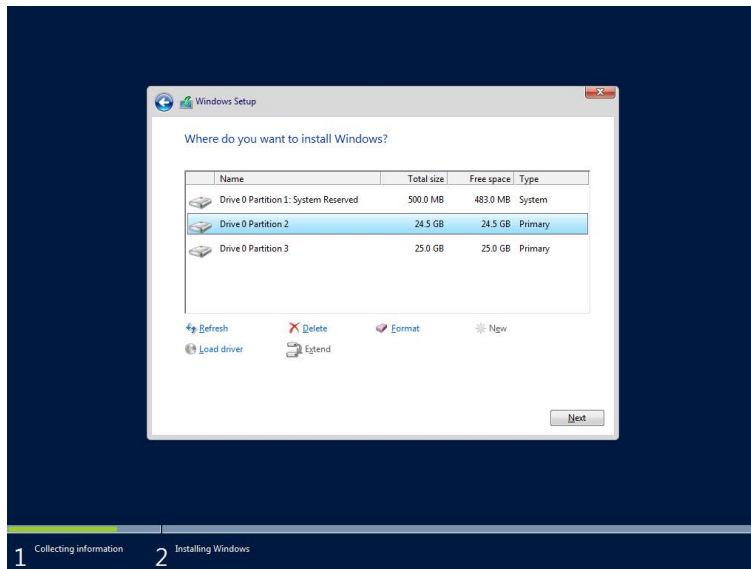

The drive is already in use and you want to install the operating system.

1. Mark the system partition (usually 500 MB in size).
2. Click <Format>.

3. Confirm with <OK>.
4. Mark the primary partition (normally the smaller one).
5. Click <Format>.
6. Confirm with <OK>.
7. Click <Next> and continue with chapter ↗ *Completing installation, page 47*.

9.2.4 Completing installation

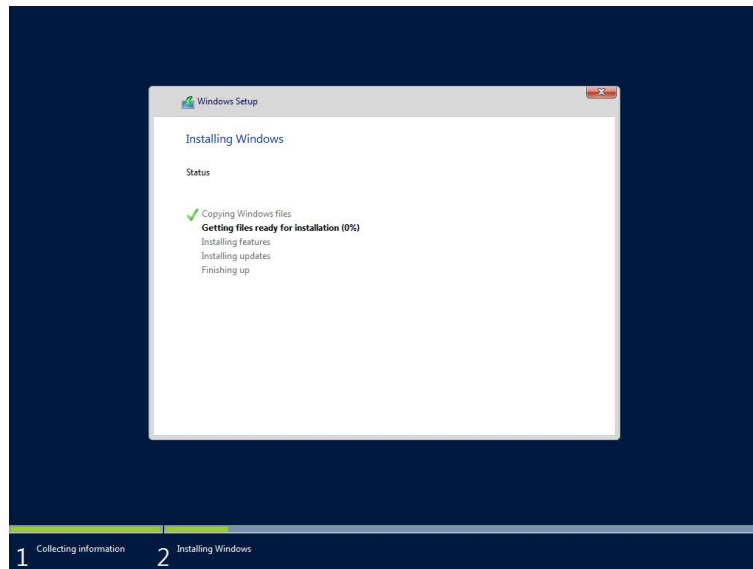

The system files are copied to the drive and additional software is installed.

The computer will restart twice.

The procedure takes 30-40 min. depending on the hardware.

9.3 Windows Updates

The automatic search for updates is deactivated by default on iba systems, as iba does not know which Windows update policies apply in your company.

Please adjust the settings according to the update policies in your company. Consult your IT department if necessary.

9.4 Installing antivirus software

There is no antivirus software installed on iba systems in delivery state.

Please install the antivirus software package which is used in your company by default. Consult your IT department if necessary.

9.5 Installing iba software

The installation of iba software is described in the manuals included in delivery.

10 Technical data

In the following you will find the technical data and dimensions for *ibaRackline-PC CAM/HD*.

10.1 Main data

Manufacturer	iba AG, Germany
Operating temperature range	32 °F to 131 °F (0 °C to 55 °C)
Storage temperature range	-13 °F to 158 °F (-25 °C to 70 °C)
Transport temperature range	-13 °F to 158 °F (-25 °C to 70 °C)
Cooling	Fan cooling
Fan current	40 mA to 400 mA
Mounting	19" rack mounting
Humidity class	F, no condensation
Protection class	IP20
Power supply	
Redundant power supply unit with changeable frame	AC 100 V to 240 V DC 90 V to 120 V / 220 V (+/- 10 %) 8 A/4 A 47 Hz to 63 Hz
Power output	1 x redundant 500 W
Mechanical data	
Dimensions (height x width x depth)	7.01 in (4 HU) x 19.02 in x 21.42 in (178 mm (4 HU) x 483 mm x 544 mm) installation depth 19.69 in (500 mm)
Weight	
ibaRackline-PC CAM/HD (5x 8 TB SAS HDD) with packaging	approx. 18.5 kg
ibaRackline-PC CAM/HD (5x 8 TB SAS HDD) without packaging	approx. 14.8 kg
ibaRackline-PC CAM/HD (5x 12 TB SAS HDD) without packaging	approx. 15.0 kg
ibaRackline-PC CAM/HD (5x 24 TB SAS HDD) without packaging	approx. 15.2 kg

10.2 Electronic components and interfaces

Processor	Intel® Xeon E 2176G, 3.7 GHz
Motherboard	Industrial mainboard with C246 chipset and LGA1151 socket
Integrated battery	Lithium button cell CR2032
Graphics on board	Integrated Intel UHD graphics
Ethernet on board	2x 10 Mbps/100 Mbps/1000 Mbps
HD audio on board	Realtek ALC892
Main memory	32 GB DDR4
PCI Express x16: SAS controller	Broadcom MegaRAID 9560-8i
PCI Express, free	5x for iba measuring cards
PCI free	1x
M.2	1x M-Key (2242/2260/2280), PCI-e 4 1x A-Key (2230), supports WiFi module
USB 2.0	2x frontside (1x dongle, 1x frontside)
USB 3.0	8x rear side
LAN	2x rear side
Graphic	1x VGA, 1x HDMI, 1x DP
Drive frame	5x 3,5" SAS
Hard disk	5x 8 TB SAS HDD (ca. 32 TB net capacity) 1x 512 GB NVMe SSD (as buffer for the HD data ¹⁾)

10.3 Products

PC systems	Order no.
ibaRackline-PC CAM, XEON E, Win 10	40.005021
ibaRackline-PC HD, XEON E, Win10	40.005031
Enhancement options	
Win11 OS Installation Request	43.000381
Upgrade to server operating system	43.000380
Upgrade ibaRackline-PC CAM with Quadro P2200	43.001001
Upgrade iba-PC with NVME-SSD 512 GB	43.001003
Upgrade HD 5x 8 TB to 5x 12 TB SAS	43.001023
Upgrade HD 5x 8 TB to 5x 24 TB SAS	43.001024
Upgrade to RAID6-System, SAS HDD 1200 GB	43.001206
Upgrade to RAID6-System, SAS HDD 2400 GB	43.001216

¹⁾ only included in ibaRackline-PC HD

PC systems	Order no.
Upgrade to RAID6-System, SAS SSD 1600 GB	43.001306
Upgrade to RAID6-System, SAS SSD 3200 GB	43.001316
Accessories	
Hard disk 12 TB SAS 3,5"	43.000359
Hard disk 24 TB SAS 3,5"	43.000361
ibaOut-State	11.110002
DVD drive, (R/W) external via USB	43.000631
Intel PCIe 10/100/1000 Mbit network card, single port	43.000525
Intel GigE-Network Card PCI Express (Dual-port Gigabit Ethernet, I350 T2)	19.116012
Intel GigE-Network Card PCI Express (Quad-port Gigabit Ethernet, I350 T4 V2 SVR)	19.116011

10.4 Dimensions

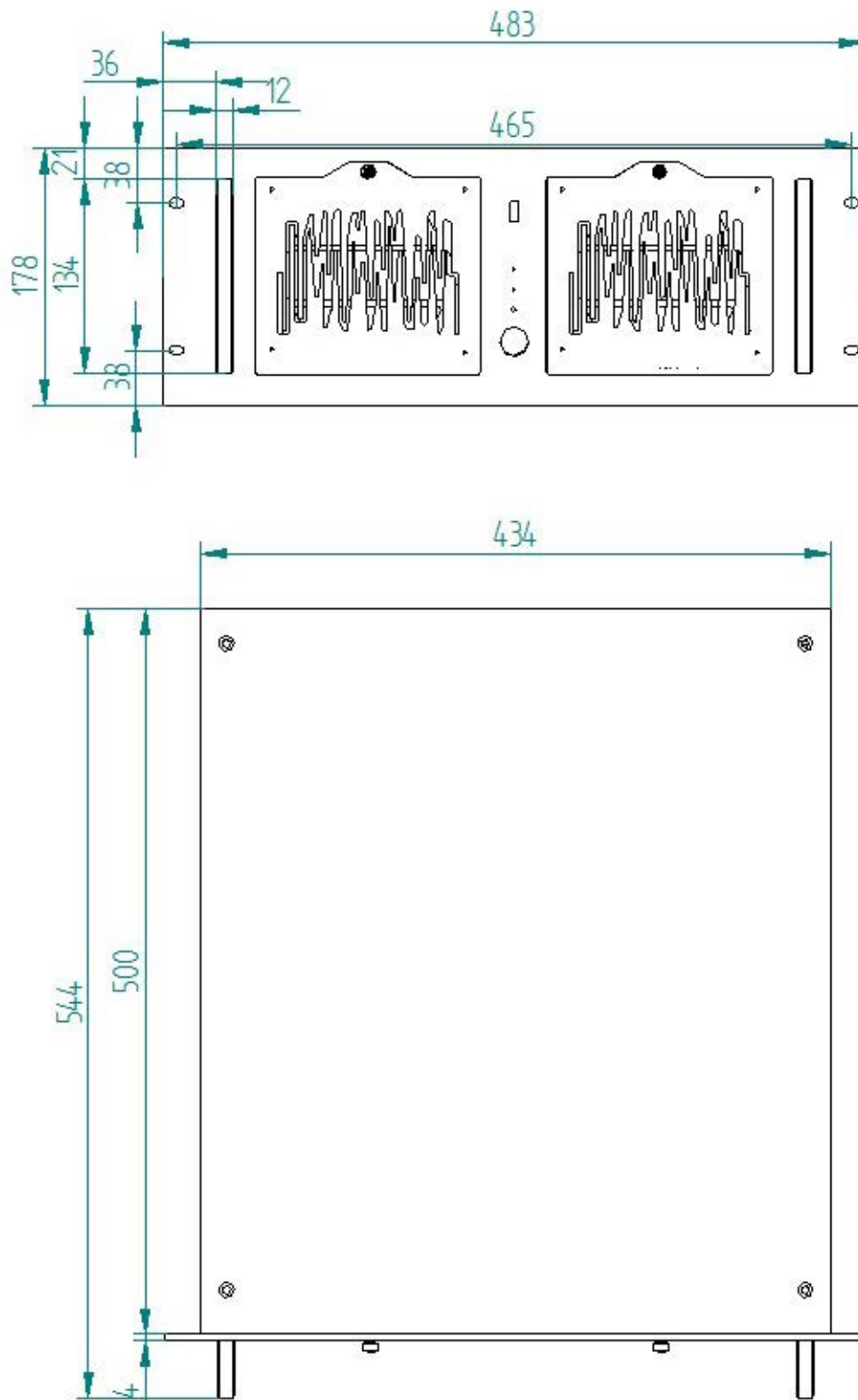

Dimensions in mm

11 Support and contact

Support

Phone: +49 911 97282-14

Email: support@iba-ag.com

Note



If you need support for software products, please state the number of the license container. For hardware products, please have the serial number of the device ready.

Contact

Headquarters

iba AG
Gebhardtstrasse 10-20
90762 Fuerth
Germany

Phone: +49 911 97282-0

Email: iba@iba-ag.com

Mailing address

iba AG
Postbox 1828
D-90708 Fuerth, Germany

Delivery address

iba AG
Gebhardtstrasse 10
90762 Fuerth, Germany

Regional and worldwide

For contact data of your regional iba office or representative please refer to our web site:

www.iba-ag.com